

PREMIERONE™

MUV7-200QR MultiVoltage UVC System

Installation & Maintenance Instructions

UNPACKING THE UNIT

Each unit is shipped with the germicidal lamps placed in a box with protective packaging. When handling lamps take care to not touch the glass portion of the lamp with bare hands. Oils from the hands can cause “hot spots” which reduce lamp life. Handle by the end caps or use a soft cloth. If you accidentally touch a lamp, use the alcohol pad included or clean it using a soft cloth dampened with rubbing alcohol. The lamp is fragile and proper care must be taken when removing from packaging.



The following parts are included:

- Power Supply
- Four (4) Germicidal Twin H Lamps (packed in lamp boxes)
- Twenty (20) Sheet Metal Screws
- Eight (8) Caution Labels
- Strain Relief Connector
- Alcohol Pad for Cleaning Lamps
- Installation & Maintenance Instructions

IMPORTANT: SAFETY INSTRUCTIONS Important: Instructions de sécurité

When installing and using this electrical equipment, basic safety precautions should always be followed including the following:

- 1. READ AND FOLLOW ALL INSTRUCTIONS.**
2. Always be sure the unit is unplugged during installation or service procedures.
3. **The ultraviolet light produced by the UV lamp is harmful to your eyes. Do not look directly at the lamp. Should it become necessary to view the lamp, use UV-protected safety goggles.**

Lors de l'installation et de l'utilisation de cet équipement, des précautions devront être suivies.

- 1- Lire et suivre les étapes attentivement.**
2. **Assurez vous de toujours débrancher avant l'installation ou le service.**
- 3- **Ne pas regarder la lampe directement avec les yeux. Si nécessaire de le faire, veuillez porter les lunettes de soleil contre les rayons U.V.**

INSTALLATION:

- Do not locate the germicidal lamps in direct sight of plastic material that will be exposed to the UV light, such as wiring, return-side humidifier or certain types of air filters. Check with the filter manufacturer to see if their material is UV resistant. Over time, UV light may degrade plastic.

- Do not touch the glass portion of the lamps with bare hands because oils from the hands can cause “hot spots” which reduce lamp life. Handle either by the end caps or use a soft cloth. If you accidentally touch a lamp, wipe it off, using the included alcohol cleaning pad or a soft cloth dampened with rubbing alcohol.

INSTALLING THE GERMICIDAL UNIT

MOUNTING GERMICIDAL LAMP AND POWER SUPPLY (supply or return side plenum)

1. Unplug mid-cord connector by pressing the lock release (marked “PRESS” on the connector.) (see photo B)
Remove two thumb nuts holding moisture resistant lamp socket to mounting plate and remove from the plate.
2. Using the lamp mounting plate as a template, draw the hole pattern on the air duct in a suitable location.
Do not install the UVC lamps where there is a straight line of sight of the lamps through a vent.
When choosing a location to mount the lamps, make certain no UV light is visible to the consumer.
3. Using a 1 1/4 inch Vari-Bit®, make two holes side by side. Clean off excess metal between the two holes with tin snips. Alternately cut a 2” hole.
4. Peel off the gasket backing from lamp mounting plate and center over hole. Secure using four self-tapping sheet metal screws provided. Repeat steps 1-4 for the other three lamps.
5. Find a suitable location to mount the power supply making sure supply cord to ballast will reach 120 or 240 volt power supply. Mount the power supply using four self-tapping sheet metal screws provided.
6. Taking care not to touch the glass, hold the lamp by the end cap and insert fully into the base plate.
7. Insert the moisture resistant lamp socket over the plastic lamp end fitting over the mounting studs, secure using the two thumb nuts. (Photo B)
8. Route cord back to the moisture resistant lamp socket and reconnect mid-cord connector. Be sure to line up arrows on the connector. (Photo A) Repeat steps 6-8 for the second lamp.
9. Adhere included UV Warning Label next to the access point in ductwork for servicing the lamps.

Photo A



Photo B



WIRING/FUSE

The multivoltage ballast is self-adjusting and operates with voltages from 120 - 240 VAC. For 120V wiring connect the black wire to L1, white wire to neutral, green wire to ground. For 240V wiring install 5 amp inline fuses to both legs of power, then connect the black wire to L1, white wire to L2, green wire to ground. Be sure power cord is secured with included strain relief connector.

It is recommended you interlock with the system blower or install a blower door safety switch so the unit powers off when the system is serviced. Connect in accordance with local wiring codes.

CORRECT WIRING FOR FOUR LAMP OPERATION.

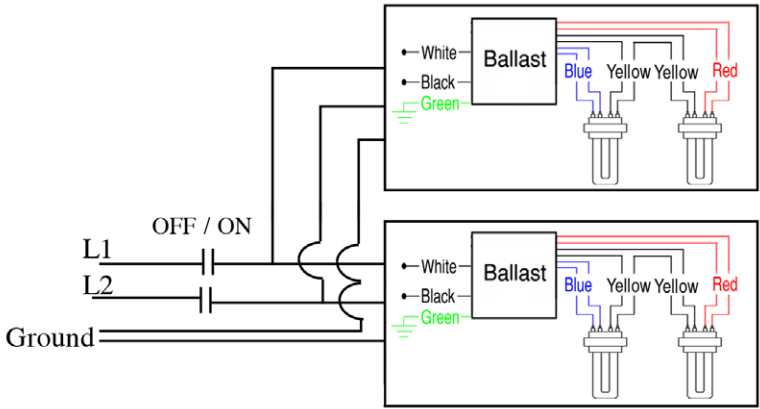
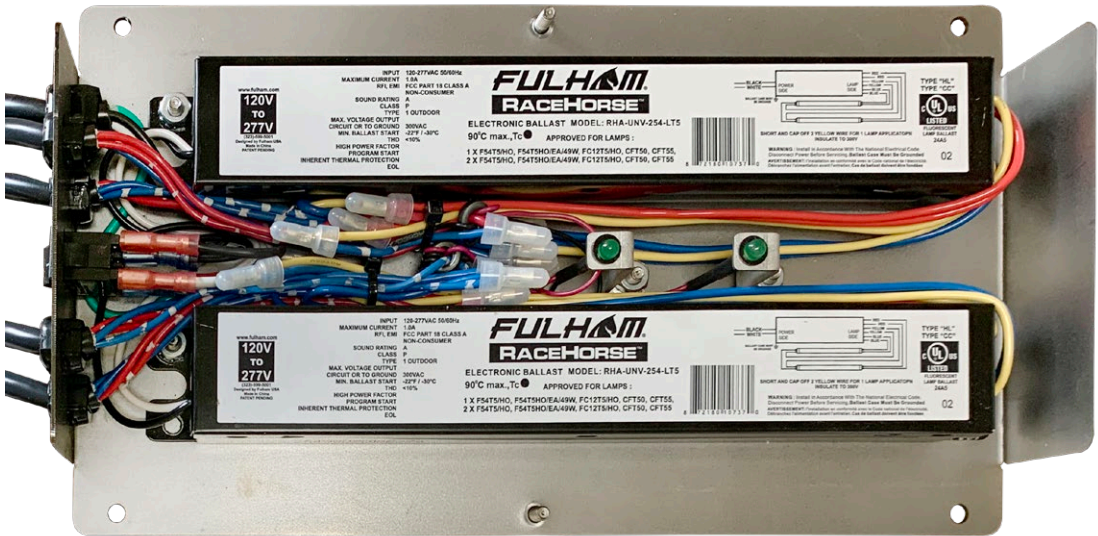
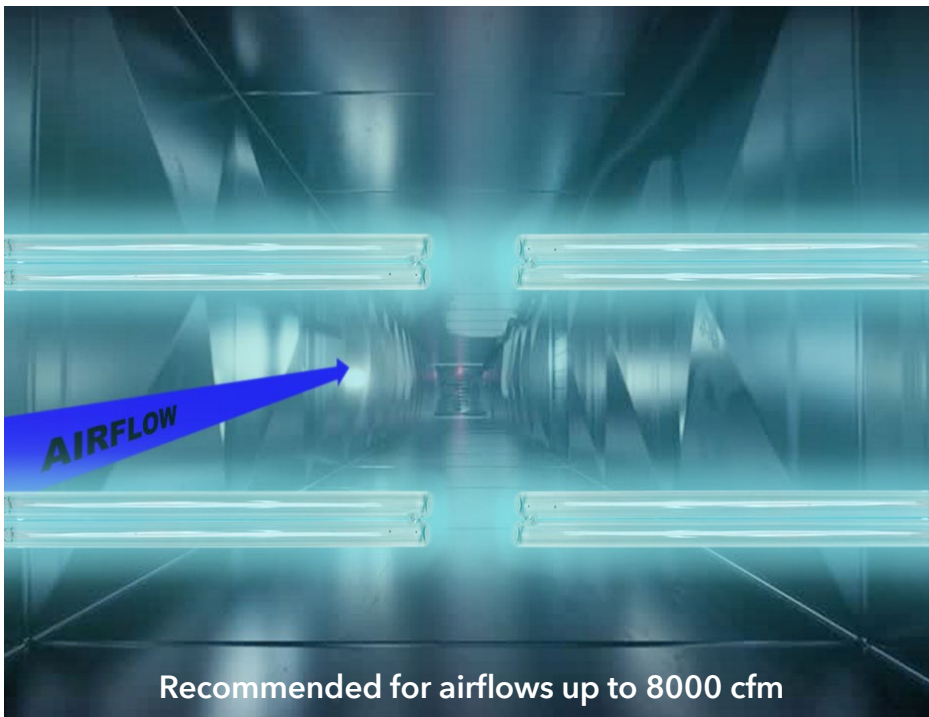

Illustration #1 Ballast 1 & 2, (2 lamps per ballast)

For best results, lamps need to be mounted on the same plane in order to get the combined microwatts to be sufficient for the air volume. Lamps should be mounted with as much distance upstream and downstream as possible. Example: in a ten (10) foot duct, lamps should be mounted at five (5) feet allowing five feet on each side of the lamps. A three (3) foot duct would be centrally mounted leaving a 1.5 feet on each side of the lamp. This should be considered the minimum distance.

Do not install the UVC lamps where there is a straight line of sight of the lamps through a vent. When choosing a location to mount the lamps, make certain no UV light is visible to the consumer.



According to Westinghouse® this is the minimum duct length to achieve a 70-85% kill/deactivation of microorganisms in a forced air system at 2000CFM using one 16" lamp.

All parameters based off end-of-life output (110 $\mu\text{W}/\text{cm}^2$)

Airflow	Duct length needed
500 FPM	36"
250 FPM	22"

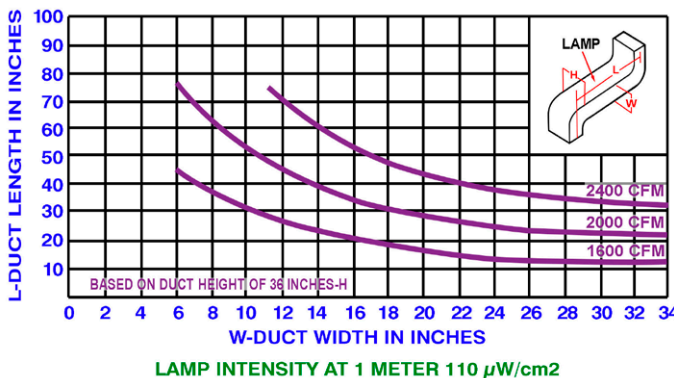

Power Supply Dimensions:
Size (L x W x D)
10.625h x 5.75w x 1.75 d

Lamp Socket Dimensions:
Size (L x W x D)
3.5" x 2.75" x 1.625"

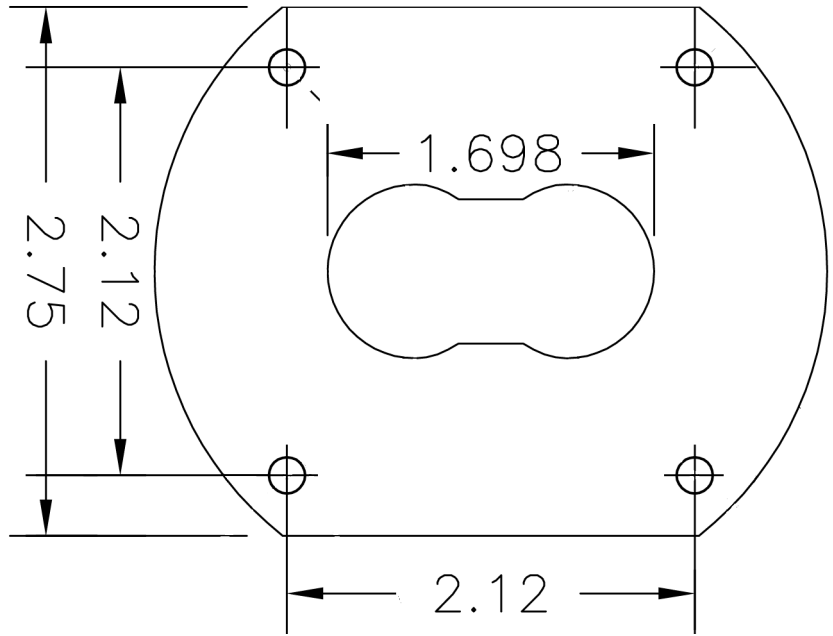

1. Using the lamp mount as a template, draw the hole pattern on the air duct in a suitable location.
2. Using a 1 1/4 inch Vari Bit, make two holes side by side. Clean off excess metal between the two holes with tin snips.
3. Peel off the adhesive backing of the gasket on backside of mounting plate.
4. Center mounting plate on hole.
5. Use four self tapping screws provided to secure mounting plate on the air duct.

TROUBLESHOOTING

With the selector switch in the ON position, the LED should light when power is supplied to the unit.

If the LED does not light with switch in the On position:

1. Check to be sure there is power to the unit.
2. Be sure lamp connectors are fastened securely.
3. If the LED still does not light, replace lamp(s).
4. If still not operating, replace ballast.

Note: Standard off-the-shelf lamps are not compatible with this unit. Use of improper lamps will void warranty.

WARRANTY RETURNS

All electronic components carry a lifetime warranty to the original homeowner. In addition there is a four-year warranty from the date of installation for any subsequent owner. The original lamp is warranted for a period of two years. This warranty does not cover broken lamps due to shipping, installation or handling. Please see the complete warranty statement on the back page of this booklet.

All returns are routed through your wholesaler and must be approved and accompanied by an RGA number. Please call PremierOne Products, Inc. at 800-982-1840 and we will guide you through the return procedure.

This warranty gives you specific legal rights and you may also have other rights which vary from state to state.

MAINTENANCE

This maintenance schedule is only a guideline, determined by average conditions. Actual conditions will dictate the frequency of cleaning and/or replacement of lamps. Do not touch the glass portion of the lamps with bare hands because oils from the hands can cause “hot spots” which reduce lamp life. Handle either by the end caps or use a soft cloth. If you accidentally touch a lamp, clean it using a soft cloth dampened with rubbing alcohol.

CLEANING THE GERMICIDAL LAMP - Recommended interval: 12 months

1. Disconnect power to the unit.
2. Unplug mid-cord connectors by pressing the lock release (marked “PRESS” on the connector.)
Remove two thumb nuts holding moisture resistant lamp socket to mounting plate and carefully remove the lamp socket with lamp from the mounting plate. Repeat this step for the other three lamps.
3. Use a soft cloth moistened with rubbing alcohol to wipe down each lamp. If there is a large build-up of dust particles, you may wish to use a can of air first. Do not touch the glass portion of the lamps with bare hands.
4. Carefully slide the moisture lamp socket with lamp through the mounting plate into duct fitting over the mounting studs and secure using the two thumb nuts. (Photo A)
5. Reconnect the mid-cord connector. Be sure to line up arrows on the connector. (Photo B)
Repeat this step for the other three lamps.
6. Supply power to the unit.

REPLACING THE LAMP - Recommended interval: 24 months

Replacement lamps are available through your HVAC contractor.

Follow above procedure except #3 where you replace the lamps instead of cleaning them.

(Note: standard off-the-shelf lamps are not compatible with this unit. Use of improper lamps will void warranty.)



LSK200-16



LSK200-12

LAMP KITS FOR MUV7-200QR

#LSK200-16 UVC lamp service kit with four (4) 16” UV lamps - 36-Watt each.

#LSK200-12 UVC lamp service kit with four (4) 12” UV lamps - 24-Watt each.

LIMITED WARRANTY

- Limited Warranty.** Except as set forth herein, PremierOne Products, Inc. ("PremierOne") warrants MUV7-200QR-16, MUV7-200QR-12, (the "Product") to be free from defects in manufacturing, materials, and workmanship for the life of the Product; provided, however, that such warranty shall only apply to the customer who originally purchased the Product (the "Limited Warranty"). With respect to a party, who is not the original purchaser of the Product, PremierOne's Limited Warranty shall extend to said party for, only, a period of four (4) years from the date of the Product's original purchase by the original customer.
- Remedy.** In the event of a Product failure as the result of a defect in manufacturing, materials, or workmanship. PremierOne, at its option, will: (a) provide to the customer the appropriate replacement for the defective Product; or (b) repair the Product found to be defective. In the event that PremierOne elects to repair or replace the Product, such repaired or replaced Product shall be warranted, as set forth in this Limited Warranty, for the lifetime of such repaired or replaced Product.
- Warranty Exclusions.** This Limited Warranty is the only express warranty (written or oral), applicable to the Product and no individual or entity is authorized to modify or expand this Limited Warranty. While warranty claims must be processed through, and approved by, a PremierOne wholesaler/reseller and accompanied by a "RGA Number," customers are encouraged to call PremierOne at (800) 982-1840 for assistance and guidance through the claim procedure.

ALL IMPLIED WARRANTIES, INCLUDING, BUT NOT LIMITED TO, IMPLIED WARRANTIES FOR MERCHANTABILITY AND FITNESS FOR A PARTICULAR PURPOSE, ARE HEREBY DISCLAIMED. PREMIERONE EXPRESSLY DISCLAIMS ALL WARRANTIES NOT STATED IN THIS LIMITED WARRANTY. ANY IMPLIED WARRANTIES THAT MAY BE IMPOSED BY LAW ARE LIMITED IN DURATION TO THE TERMS OF THIS LIMITED WARRANTY. IN NO EVENT WILL PREMIERONE BE LIABLE TO A CUSTOMER, OR ANY THIRD PARTY, FOR ANY DAMAGES IN EXCESS OF THE PURCHASE PRICE OF THE PRODUCT ALLEGED TO BE DEFECTIVE. IN ADDITION, PREMIERONE SHALL IN NO EVENT BE LIABLE TO A CUSTOMER, OR ANY THIRD PARTY, FOR ANY DIRECT OR INDIRECT DAMAGES OR OTHER SPECIAL, INCIDENTAL, EXEMPLARY OR CONSEQUENTIAL DAMAGES ARISING OUT OF THE FAILURE OF THE PRODUCT TO COMPLY WITH THIS LIMITED WARRANTY, INCLUDING, BUT NOT LIMITED TO, DAMAGE OR LOSS OF OTHER PROPERTY OR EQUIPMENT. THE REMEDIES OF CUSTOMER SET FORTH IN THIS LIMITED WARRANTY ARE EXCLUSIVE. NOTWITHSTANDING ANYTHING CONTAINED HEREIN TO THE CONTRARY, PREMIERONE'S LIABILITY WITH RESPECT TO THE PRODUCT, IN ALL INSTANCES, SHALL BE LIMITED TO THE REPAIR OR REPLACEMENT OF THE PRODUCT ALLEGED TO BE DEFECTIVE.

Some states do not allow the exclusion or limitation of incidental or consequential damages or limitation of the duration of an implied warranty, so the above limitations or exclusions may not apply to the customer. This Limited Warranty gives the customer specific legal rights, and the customer may also have other rights which may vary from jurisdiction to jurisdiction.

- Additional Warranty Exclusions.** In addition to the exclusions set forth above, this Limited Warranty does not cover Product defects, including lamps, caused, in whole or in part, by any one or more of the following circumstances or conditions: (a) adjustments or corrections to Product due to improper Product installation; (b) improper assembly or improper Product installation; (c) Product failure due to the application or installation of non-PremierOne approved accessories, pieces, hardware, and additions including, but not limited to, installation and use of other than a genuine PremierOne lamp designed specifically for the Product; (d) failure to properly install related Product accessories, pieces, hardware, and additions including, but not limited to, customer's failure to replace the Product's lamp(s) every two (2) years; (e) Product exposure to conditions outside of the scope of PremierOne's Product performance specifications; (f) improper maintenance and care of the Product, before, during, or after installation including, specifically, breakage of Product lamps during shipping and installation or caused by improper handling; (g) modification or refabrication, partial or otherwise, of the Product; and (h) accidents.

This Limited Warranty does not cover any labor, including labor related to the removal, replacement, installation, or disposal of a defective Product.

PremierOne warrants that, subject to the exceptions set forth in Section 4, above, genuine PremierOne lamps shall function as intended for a period of two (2) years from date of Product installation or, as the case may be, from the date of customer's purchase of a genuine PremierOne replacement lamp.

- Miscellaneous.** The rights and obligations of the parties hereunder shall be interpreted and governed in accordance with the laws of the State of Wisconsin. Any claim, dispute, controversy, or action arising out of or related to the enforcement of this Limited Warranty, regardless of the existence and nature of any purchase and sale documents related to the Product, shall be filed or brought in the Brown County Circuit Court, Green Bay, Wisconsin, or in the United States Federal District Court for the Eastern District of Wisconsin, Green Bay, Wisconsin. If any provision of this Limited Warranty is deemed or held to be illegal, invalid, or unenforceable, under any present or future laws of any applicable jurisdiction, this Limited Warranty shall be considered divisible and inoperative as to such provision to the extent it is deemed to be illegal, invalid, or unenforceable, and in all other respects, this Limited Warranty shall remain in full force and effect.