

PREMIERONE™

MUV-403H MultiVoltage Oxidizing UVC System

Installation & Maintenance Instructions

UNPACKING THE UNIT

Each unit is shipped with the 5” lamp installed and the germicidal lamp placed in a box with protective packaging. Carefully remove lamp from the tube taking care to not touch the glass portion of the lamp with bare hands. Oils from the hands can cause “hot spots” which reduce lamp life. Handle by the end caps or use a soft cloth. If you accidentally touch a lamp, clean it using the included alcohol cleaning pad or a soft cloth dampened with rubbing alcohol. The lamp is fragile and proper care must be taken when removing from packaging.



- The following parts are included:**
- MUV-403H Unit
 - Germicidal Twin H Lamp (packed in lamp box)
 - Four Sheet Metal Screws
 - Installation & maintenance instructions
 - 120 VAC Power Cord (PC-120)
 - Alcohol pad for cleaning lamps

IMPORTANT: SAFETY INSTRUCTIONS Important: Instructions de sécurité

When installing and using this electrical equipment, basic safety precautions should always be followed including the following:

- 1. READ AND FOLLOW ALL INSTRUCTIONS.**
2. Always be sure the unit is unplugged during installation or service procedures.
3. **The ultraviolet light produced by the UV lamp is harmful to your eyes. Do not look directly at the lamp. Should it become necessary to view the lamp, use UV-protected goggles.**

Lors de l'installation et de l'utilisation de cet équipement, des précautions devront être suivies.

- 1- Lire et suivre les étapes attentivement.**
- 2- Assurez vous de toujours débrancher avant l'installation ou le service.**
- 3- **Ne pas regarder la lampe directement avec les yeux. Si nécessaire de le faire, veuillez porter les lunettes de soleil contre les rayons U.V.**

INSTALLATION:

If there is a device that creates ozone in the space such as an ionizing air cleaner, it is recommended the oxidizing unit not be used in this application. Use one of our germicidal only models instead. Homes with multiple air handlers: install this unit on the main level air handler and a germicidal only model on the other air handler(s).

- Do not locate the germicidal lamps in direct sight of plastic material that will be exposed to the UV light, such as wiring, return-side humidifier or certain types of air filters. Check with the filter manufacturer to see if their material is UV resistant. Over time, UV light may degrade plastic.
 - Do not install the UVC lamps where there is a straight line of sight of the lamps through a vent. When choosing a location to mount the lamps, make certain no UV light is visible to the consumer.
 - Do not touch the glass portion of the lamps with bare hands because oils from the hands can cause “hot spots” which reduce lamp life. Handle either by the end caps or use a soft cloth. If you accidentally touch a lamp, wipe it off, using the included alcohol cleaning pad or a soft cloth dampened with rubbing alcohol.
1. Cut out the shaded area of the installation template. (Please see insert.)
 2. Center the template on the longitudinal axis of the plenum and attach with tape. Trace the hole pattern for the unit and mark centers for mounting screws. (Airflow direction is marked on the unit.)
 3. Cut openings for the unit using a 2” hole saw or tin snips.
 4. Remove the cover from the unit by removing the top and bottom retaining nuts using an 11/32 size nut driver and set aside. Do not remove the oxidation control knob. (For easier installation rotate control knob to the center position before removing cover.)
 5. Attach the unit to the air duct using the four self tapping sheet metal screws provided.
 6. Remove the germicidal lamp holder using a 11/32 size nut driver (Figure A).
 7. Slide the germicidal lamp into lamp opening.
 8. Reinstall the lamp holder and plug lamp into connector.
 10. Replace cover and align the oxidizing control knob with adjustment linkage by gently turning the knob until the linkage clicks into place. Secure cover using the two retaining nuts.

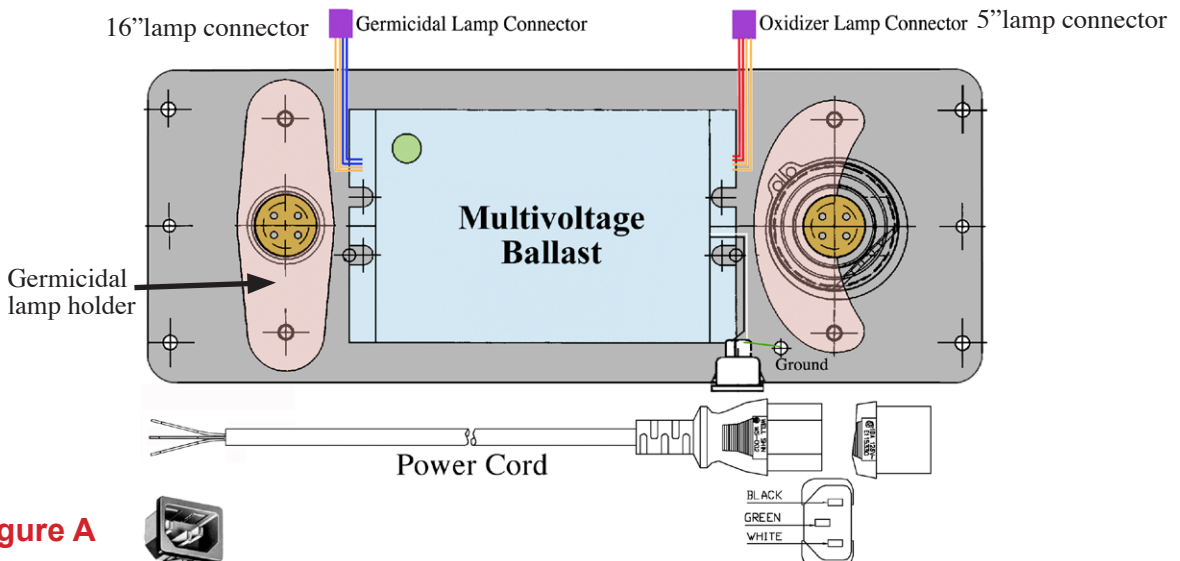

Figure A



WIRING OPTION 1

The multivoltage ballast is self-adjusting and operates with voltages from 120 - 240 VAC. This unit must cycle with the furnace blower. Install provided power cord and wire the unit to an EAC terminal or current-sensing relay to cycle the unit with the system fan. Connect in accordance with local wiring codes. For 120V wiring connect the black wire to L1 or EAC terminal, white wire to neutral, green wire to ground. Be sure power cord is secured with a strain relief connector. After installing verify voltage is operating at 110-120 VAC with air handler operating.

WIRING OPTION 2

For hard wiring to 240V systems install 5 amp in-line fuses to both legs of power. Then connect the black wire to L1, white wire to L2, green wire to ground. Use a current-sensing relay or 24 V contactor to cycle the unit. Be sure power cord is secured with a strain relief connector. Wire the unit in accordance with local wiring codes. After installing, verify voltage is operating between 208-240 VAC with air handler operating.

SETTING THE ACTIVATED OXYGEN OUTPUT LEVEL

- The air purification process occurs only while air is circulating through the HVAC system.
- The oxidizing level can be easily adjusted as needed using the “Oxidation Odor Control” knob on the front of unit. Start with the setting in the normal range. Decrease the setting if an activated oxygen odor is detectable. If household odors are noticeable after 24 hours, increase the setting

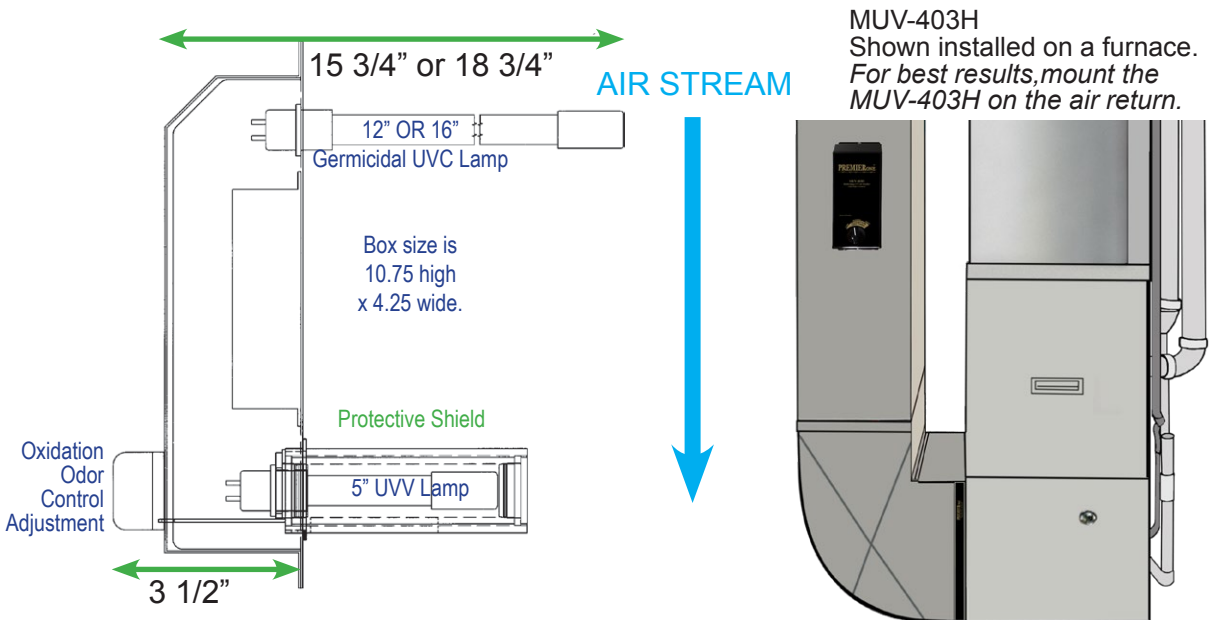

For Technical Support Call (800)982-1840

TROUBLESHOOTING

- The LED should light when the furnace blower is running.
- Both lamps use the same multivoltage ballast.

If the LED does not light:

1. Check to be sure there is power to the unit.
2. Be sure lamp connectors are fastened securely.
3. If the LED still does not light, replace lamp(s).
4. If still not operating, replace ballast.

Note: Standard off-the-shelf lamps are not compatible with this unit. Use of improper lamps will void warranty.

WARRANTY RETURNS

All electronic components carry a lifetime warranty to the original homeowner. In addition there is a four-year warranty from the date of installation for any subsequent owner. The original lamp is warranted for a period of two years. This warranty does not cover broken lamps due to shipping, installation or handling. Please see the complete warranty statement in the center of this booklet.

All returns are routed through your wholesaler and must be approved and accompanied by an RGA number. Please call PremierOne Products, Inc. at 800-982-1840 and we will guide you through the return procedure.

This warranty gives you specific legal rights and you may also have other rights which vary from state to state.

MAINTENANCE

This maintenance schedule is only a guideline, determined by average conditions. Actual conditions will dictate the frequency of cleaning and/or replacement of lamps. Do not touch the glass portion of the lamps with bare hands because oils from the hands can cause “hot spots” which reduce lamp life. Handle either by the end caps or use a soft cloth. If you accidentally touch a lamp, clean it using a soft cloth dampened with rubbing alcohol.

CLEANING THE LAMPS - Recommended interval: 12 months (Follow the procedure below)

Replacement lamps are available through your HVAC contractor.

REPLACING THE LAMPS - Recommended interval: 24 months. (Follow procedure below excluding #6.)

Note: Standard off-the-shelf lamps are not compatible with this unit. Use of improper lamps will void warranty.

1. Unplug the power cord from the outlet, or disconnect power to the unit.
2. Remove the cover from the unit by removing the top and bottom retaining nuts using a 11/32 size nut driver. Do not remove the Oxidation Control knob. (It helps to rotate the control knob to the center position before removing cover.)
3. Unplug the lamp from each lamp connector.
4. Remove lamp holders using a 11/32 size nut driver (Figure A).
5. Remove each lamp by grasping the end cap and extract carefully.
6. Using a soft cloth moistened with rubbing alcohol, wipe down each lamp. If there is a large build-up of dust particles, you may wish to use a can of air first. Always handle lamps by end caps.
7. Slide one lamp back into lamp opening. Reinstall lamp holder.
8. Repeat step 7 for second lamp.
9. Plug each lamp into the corresponding lamp connector.
10. Replace cover and align the oxidation control knob with the adjustment linkage by gently turning the knob until linkage clicks into place. Secure cover using the two retaining nuts.
11. Plug power cord back into outlet, or restore power to unit.

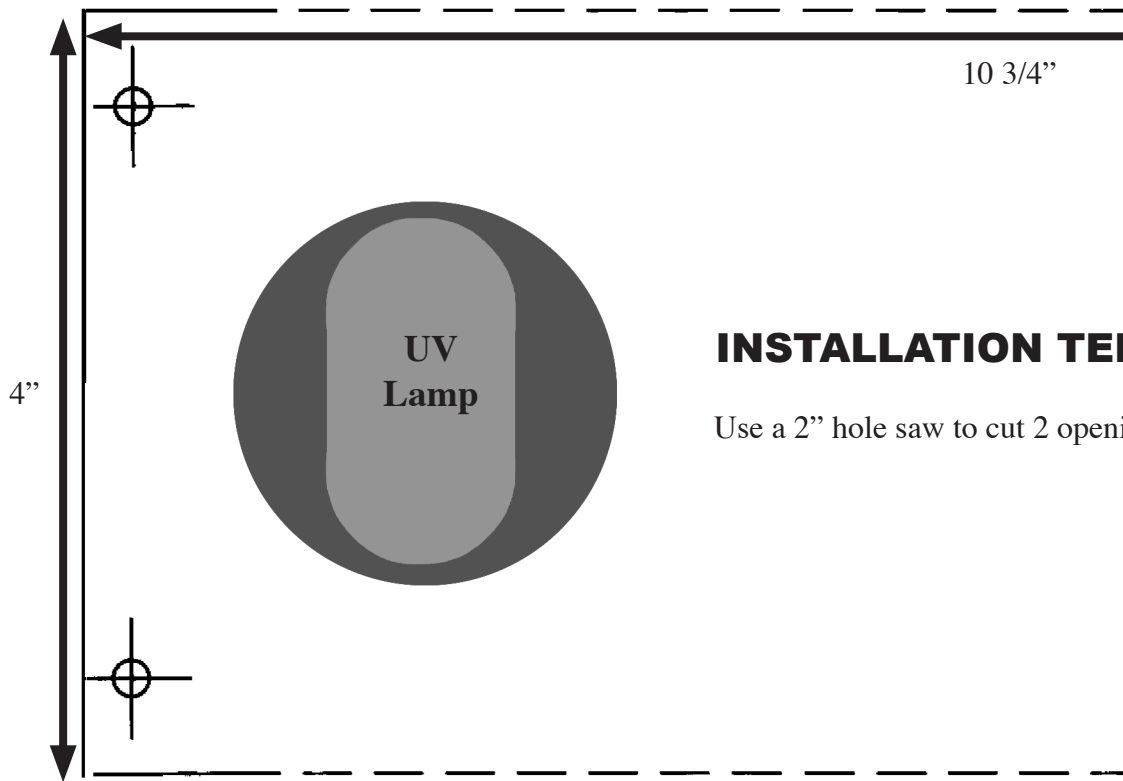

1. Cut out area of template indicated by the two circles if using a hole saw.
2. Place template on the return path of the HVAC system and trace the hole pattern for the unit and mark centers for mounting screws. Unit must be oriented so long dimension is parallel to the direction of the air flow parallel to the direction of the air flow.
3. Cut opening for the unit.
4. Install unit into air duct so that airflow matches direction indicated on side of unit using the four self tapping sheet metal screws provided.

PLATE MUV-403H

ings indicated by the gray circles.



LSK07403H-16/5



LAMP KITS FOR MUV-403H

#LSK07403H-16/5 44-Watt UVC/UVV lamp service kit with 16" UV lamp.

#LSK07403H-12/5 36-Watt UVC/UVV lamp service kit with 12" UV lamp.

LIMITED WARRANTY

- 1. Limited Warranty.** Except as set forth herein, PremierOne Products, Inc. ("PremierOne") warrants MUV-403H 16/5 and MUV-403H 12/5 (the "Product") to be free from defects in manufacturing, materials, and workmanship for the life of the Product; provided, however, that such warranty shall only apply to the customer who originally purchased the Product (the "Limited Warranty"). With respect to a party, who is not the original purchaser of the Product, PremierOne's Limited Warranty shall extend to said party for, only, a period of four (4) years from the date of the Product's original purchase by the original customer.
- 2. Remedy.** In the event of a Product failure as the result of a defect in manufacturing, materials, or workmanship. PremierOne, at its option, will: (a) provide to the customer the appropriate replacement for the defective Product; or (b) repair the Product found to be defective. In the event that PremierOne elects to repair or replace the Product, such repaired or replaced Product shall be warranted, as set forth in this Limited Warranty, for the lifetime of such repaired or replaced Product.
- 3. Warranty Exclusions.** This Limited Warranty is the only express warranty (written or oral), applicable to the Product and no individual or entity is authorized to modify or expand this Limited Warranty. While warranty claims must be processed through, and approved by, a PremierOne wholesaler/reseller and accompanied by a "RGA Number," customers are encouraged to call PremierOne at (800) 982-1840 for assistance and guidance through the claim procedure.

ALL IMPLIED WARRANTIES, INCLUDING, BUT NOT LIMITED TO, IMPLIED WARRANTIES FOR MERCHANTABILITY AND FITNESS FOR A PARTICULAR PURPOSE, ARE HEREBY DISCLAIMED. PREMIERONE EXPRESSLY DISCLAIMS ALL WARRANTIES NOT STATED IN THIS LIMITED WARRANTY. ANY IMPLIED WARRANTIES THAT MAY BE IMPOSED BY LAW ARE LIMITED IN DURATION TO THE TERMS OF THIS LIMITED WARRANTY. IN NO EVENT WILL PREMIERONE BE LIABLE TO A CUSTOMER, OR ANY THIRD PARTY, FOR ANY DAMAGES IN EXCESS OF THE PURCHASE PRICE OF THE PRODUCT ALLEGED TO BE DEFECTIVE. IN ADDITION, PREMIERONE SHALL IN NO EVENT BE LIABLE TO A CUSTOMER, OR ANY THIRD PARTY, FOR ANY DIRECT OR INDIRECT DAMAGES OR OTHER SPECIAL, INCIDENTAL, EXEMPLARY OR CONSEQUENTIAL DAMAGES ARISING OUT OF THE FAILURE OF THE PRODUCT TO COMPLY WITH THIS LIMITED WARRANTY, INCLUDING, BUT NOT LIMITED TO, DAMAGE OR LOSS OF OTHER PROPERTY OR EQUIPMENT. THE REMEDIES OF CUSTOMER SET FORTH IN THIS LIMITED WARRANTY ARE EXCLUSIVE. NOTWITHSTANDING ANYTHING CONTAINED HEREIN TO THE CONTRARY, PREMIERONE'S LIABILITY WITH RESPECT TO THE PRODUCT, IN ALL INSTANCES, SHALL BE LIMITED TO THE REPAIR OR REPLACEMENT OF THE PRODUCT ALLEGED TO BE DEFECTIVE.

Some states do not allow the exclusion or limitation of incidental or consequential damages or limitation of the duration of an implied warranty, so the above limitations or exclusions may not apply to the customer. This Limited Warranty gives the customer specific legal rights, and the customer may also have other rights which may vary from jurisdiction to jurisdiction.

4. **Additional Warranty Exclusions.** In addition to the exclusions set forth above, this Limited Warranty does not cover Product defects, including lamps, caused, in whole or in part, by any one or more of the following circumstances or conditions: (a) adjustments or corrections to Product due to improper Product installation; (b) improper assembly or improper Product installation; (c) Product failure due to the application or installation of non-PremierOne approved accessories, pieces, hardware, and additions including, but not limited to, installation and use of other than a genuine PremierOne lamp designed specifically for the Product; (d) failure to properly install related Product accessories, pieces, hardware, and additions including, but not limited to, customer's failure to replace the Product's lamp(s) every two (2) years; (e) Product exposure to conditions outside of the scope of PremierOne's Product performance specifications; (f) improper maintenance and care of the Product, before, during, or after installation including, specifically, breakage of Product lamps during shipping and installation or caused by improper handling; (g) modification or refabrication, partial or otherwise, of the Product; and (h) accidents.

This Limited Warranty does not cover any labor, including labor related to the removal, replacement, installation, or disposal of a defective Product.

PremierOne warrants that, subject to the exceptions set forth in Section 4, above, genuine PremierOne lamps shall function as intended for a period of two (2) years from date of Product installation or, as the case may be, from the date of customer's purchase of a genuine PremierOne replacement lamp.

5. **Miscellaneous.** The rights and obligations of the parties hereunder shall be interpreted and governed in accordance with the laws of the State of Wisconsin. Any claim, dispute, controversy, or action arising out of or related to the enforcement of this Limited Warranty, regardless of the existence and nature of any purchase and sale documents related to the Product, shall be filed or brought in the Brown County Circuit Court, Green Bay, Wisconsin, or in the United States Federal District Court for the Eastern District of Wisconsin, Green Bay, Wisconsin. If any provision of this Limited Warranty is deemed or held to be illegal, invalid, or unenforceable, under any present or future laws of any applicable jurisdiction, this Limited Warranty shall be considered divisible and inoperative as to such provision to the extent it is deemed to be illegal, invalid, or unenforceable, and in all other respects, this Limited Warranty shall remain in full force and effect.